

EXAM
DRILL

Electricity

ANSWERS

1. A heater coil should have (i) high resistivity and (ii) high melting point.

OR

The cells are connected in series, to get maximum voltage.

$$2. V_1 = IR_1 = 10 \times 2 = 20 \text{ V,}$$

$$V_2 = IR_2 = 10 \times 4 = 40 \text{ V,}$$

$$V_3 = 10 \times 6 = 60 \text{ V.}$$

$$3. R = \rho \frac{l}{A}$$

$$R_A : R_B = [(5 \times 4)/(2)^2] : [(18 \times 9)/(3)^2] = 5 : 18$$

$$4. \text{ Correct relationship will be, } 1 \text{ A} = \frac{1 \text{ C}}{1 \text{ s}}.$$

5. (a) : The smallest resistance can be obtained by combining those resistance in parallel. Thus, here smallest resistance is R/n .

6. (c) : Ammeter is always connected in series and voltmeter in parallel with the resistor.

OR

(c) : To apply a variable resistance in the circuit.

7. (a) : Resistance is inversely proportional to power of the bulb.

$$P \propto V^2/R$$

8. (b) : As we know, $V = IR$ from Ohm's law. So, if resistance is doubled, then current becomes half.

9. (c) : Resistance is directly proportional to length and inversely proportional to square of diameter.

OR

(c) : The resistors will be 3Ω and 6Ω . $R_s = 3 + 6 = 9 \Omega$

$$\text{and } R_p = \frac{3 \times 6}{3 + 6} = 2 \Omega.$$

10. Resistance, $R = 20 \Omega$; Current, $I = 5 \text{ A}$

Time, $t = 30 \text{ s}$

$$\text{Heat generated} = I^2 R t = (5 \text{ A})^2 \times 20 \Omega \times 30 \text{ s}$$

$$= 25 \times 20 \times 30 \text{ J} = 15000 \text{ J} = 15 \text{ kJ}$$

11. As power, $P = \frac{V^2}{R}$, hence more power is dissipated by 40 W bulb as it has a higher resistance. So, it will glow brightest in series.

OR

$$H = I^2 R T$$

$$80 = (2)^2 \times R \times 10$$

$$R = \frac{80}{40} = 2 \Omega$$

12. (c) : Fuse wire does not depend on its length.

OR

(a) : Nichrome is one of best heating element.

13. Charge, $Q = 1 \text{ C}$; Applied voltage, $V = 6 \text{ V}$

Then, work done in moving a charge of 1 C under the voltage of 6 V, $W = 1 \text{ C} \times 6 \text{ V} = 6 \text{ J}$

Thus, an energy of 6 J should be given during the passage of one coulomb of charge through a 6 V battery.

14. (b) : Since in the given case the voltage is same, therefore,

$$H = \frac{V^2}{R} t = \text{constant. Hence, if } R \text{ is halved, } t \text{ must be halved.}$$

15. (c) : Assertion is true but reason is false.

$$\begin{aligned} 1 \text{ kWh} &= 1 \text{ kW} \times 1 \text{ hour} \\ &= 1000 \text{ (joule/s)} \times 3600 \text{ s} \\ &= 36 \times 10^5 \text{ joule} \end{aligned}$$

i.e., kWh is the unit of electric energy and used for expressing consumed electric energy.

16. (b) : Both the assertion and reason are true but reason is not the correct explanation of assertion.

$$\text{The resistance, } R = \frac{V^2}{P}, \text{ i.e., } R \propto 1/P$$

i.e., higher is the wattage of a bulb, lesser is the resistance and so it will glow brighter.

OR

(d) : In a simple battery circuit, the point at lowest potential is the negative terminal of battery. The current flows in the circuit from positive terminal to negative terminal.

17. (i) (a) : The S.I. unit of electric power is watt (W).

(ii) (c) : Kilowatt hour is the unit of electrical energy.

$$\text{(iii) (d) : Current, } I = \frac{P}{V} = \frac{P}{RI}$$

$$I^2 = \frac{P}{R} = \frac{1}{10000}$$

$$I = \frac{1}{100} = 0.01 \text{ A}$$

(iv) (b) : Heat produced = Power \times Time
 $= 100 \times 5 \times 60 = 3 \times 10^5 \text{ J}$

(v) (b) : Here, $P = 750 \text{ W}$, $V = 200 \text{ V}$

As $P = VI$

$I = P/V = (750/200) \text{ A} = 3.75 \text{ A}$

18. (i) (c) : The equivalent resistance in the parallel combination is lesser than the least value of the individual resistance.

(ii) (b) : Resistance of each piece = $\frac{12}{3} = 4 \Omega$

$$\frac{1}{R_p} = \frac{1}{4} + \frac{1}{4} + \frac{1}{4} = \frac{3}{4} \Rightarrow R_p = \frac{4}{3} \Omega$$

(iii) (a) : All the three resistors are in parallel.

$$\therefore \frac{1}{R_p} = \frac{1}{6} + \frac{1}{3} + \frac{1}{1} = \frac{1+2+6}{6} = \frac{9}{6}$$

$$R_p = \frac{6}{9} = \frac{2}{3} \Omega$$

(iv) (a) : Voltage is same across each resistance.

So, $I_1 \times 5 = I_2 \times 10 = 15 \times I_3$

$$I_1 = 2I_2 = 3I_3$$

(v) (d) : All are in parallel.

$$\frac{1}{R_p} = \frac{1}{12} \times 4 = \frac{1}{3} \Rightarrow R_p = 3 \Omega$$

$$I = \frac{3}{3} = 1 \text{ A}$$

So, current in each resistor $I' = \frac{3}{12} = \frac{1}{4} \text{ A}$

19. (i) (b)

(ii) (c) : In series combination, resistance is maximum and in parallel combination, resistance is minimum.

(iii) (c) : $R_1 = r_1 + r_2$... (i)

$$R_2 = \frac{r_1 r_2}{r_1 + r_2} \dots (ii)$$

$$\therefore \frac{R_1}{R_2} = \frac{(r_1 + r_2)^2}{r_1 r_2}$$

(iv) (c) : In the given circuit, 3Ω resistors are in series.

$$R_s = 3 + 3 = 6 \Omega$$

Now, R_s and 6Ω are parallel.

$$\frac{1}{R_p} = \frac{1}{6} + \frac{1}{6} = \frac{2}{6} = \frac{1}{3} \Rightarrow R_p = 3 \Omega$$

(v) (a) : $V = 0.2 \times 10 = 2 \text{ V}$

So, total voltage supplied is same as 2 V .

20. (i) (a) : $V = IR$

So, $V' \rightarrow 2 \text{ V}$, $R' \rightarrow 2R$

$$I' = \frac{2V}{2R} = I$$

(ii) (b) : $V \propto I$. So, the graph is a straight line and passing through origin.

(iii) (b) : Slope of $V-I$ graph = $\frac{I}{V} = \frac{1}{R}$

(iv) (c) : Given: $V = 9 \text{ V}$, $I = 0.1 \text{ A}$

$$R = \frac{V}{I} = \frac{9}{0.1} = 90 \Omega$$

(v) (c) : On increasing the voltage, the resistance remain same, so current will increase.

21. The slope of the line in $V-I$ graph, is $\frac{V}{I} = R$

We know that resistance in series is greater than the resistance in parallel. The graph shows series resistance have greater slope and is therefore, correct.

In graph (b), the slope of the line is $\frac{I}{V} = \frac{1}{R}$ i.e., the reciprocal.

So, only graph (a) is correctly labelled.

OR

$$R_A = \rho \frac{l}{\pi r^2}; R_B = \rho \frac{2l}{\pi(2r)^2} = \rho \frac{l}{2\pi r^2}$$

$$\frac{1}{R_p} = \frac{1}{R_A} + \frac{1}{R_B} = \frac{\pi r^2}{\rho l} + \frac{2\pi r^2}{\rho l} = \frac{3\pi r^2}{\rho l}$$

$$\therefore R_p = \frac{\rho l}{3\pi r^2}$$

$$\text{Now, } \frac{R_p}{R_A} = \frac{\rho l / 3\pi r^2}{\rho l / \pi r^2} = \frac{\rho l}{3\pi r^2} \times \frac{\pi r^2}{\rho l} = \frac{1}{3}$$

(ρ is same for both resistors A and B because both are of same metal.)

22. Potential difference, $V = 24 \text{ volts}$

Resistance, $R = 120 \text{ ohms}$

and Current, $I = ?$

Now, putting these values in the Ohm's law we get,

$$\frac{V}{I} = R \text{ or } \frac{24}{I} = 120$$

So, $120I = 24$

$$\Rightarrow I = \frac{24}{120} \text{ ampere}$$

$$\therefore I = 0.2 \text{ ampere (or } 0.2 \text{ A)}$$

Thus, the current flowing in the circuit is 0.2 ampere .

23. If only resistors are connected to the battery, the source energy continually gets dissipated entirely in the form of heat. This is known as heating effect of current. The amount of heat (H) produced in time t is given by Joule's law of heating.

$$H = I^2 R t$$

Where, I is current flowing through resistor R for time t .

The electric laundry iron, electric toaster, electric oven, electric kettle and electric heater are some common devices based on heating effect of current.

OR

Here, $P = 750 \text{ W}$, $V = 200 \text{ V}$

(a) As $P = VI$

$$I = P/V = (750/200) \text{ A} = 3.75 \text{ A}$$

(b) By Ohm's law $V = IR$ or $R = V/I$

$$\therefore R = \frac{200}{3.75} \Omega = 53.3 \Omega$$

(c) Energy consumed by the iron in 2 hours

$$= P \times t = 750 \text{ W} \times 2 \text{ h} = 1.5 \text{ kWh}$$

$$\text{or } E = (750 \times 2 \times 3600) \text{ J} = 5.4 \times 10^6 \text{ J}$$

24. We know that, electrical energy = Power \times time

$$\text{or } E = P \times t \quad \dots(i)$$

We want to calculate the electrical energy in kilowatt-hours, so first we should convert the power of 120 watts into kilowatts by dividing it by 1000. That is power, $P = 120 \text{ watts}$

$$= \frac{120}{1000} \text{ kilowatt} = 0.12 \text{ kilowatt}$$

and, time, $t = 50 \text{ hours}$

Now, putting $P = 0.12 \text{ kW}$ and $t = 50 \text{ hours}$ in equation (i), we get:

$$\text{Electrical energy, } E = 0.12 \times 50 = 6 \text{ kilowatt-hours}$$

Thus, electrical energy consumed is 6 kilowatt-hours.

25. Suppose the length of 12Ω resistance wire is l , its area of cross-section is A and its resistivity is ρ . Then:

$$R = \frac{\rho \times l}{A} \quad \text{or} \quad 12 = \frac{\rho \times l}{A} \quad \dots(ii)$$

Now, when this wire is doubled up by folding, then its length will become half, that is, the length will become $\frac{l}{2}$. But on

doubling the wire by folding, its area of cross-section will become double, that is, the area of cross-section will become $2A$. Suppose the new resistance of the doubled up wire (or folded wire) is R , So,

$$R = \frac{\rho \times l}{2 \times 2A} \quad \text{or} \quad R = \frac{\rho \times l}{4A} \quad \dots(ii)$$

Now, dividing equation (ii) by equation (i), we get:

$$\frac{R}{12} = \frac{\rho \times l \times A}{4A \times \rho \times l} \quad \text{or} \quad \frac{R}{12} = \frac{1}{4}$$

$$4R = 12 \Rightarrow R = \frac{12}{4} \Rightarrow R = 3 \Omega$$

26. (a) The current can be calculated by using Ohm's law:

$$\frac{V}{I} = R$$

Here, potential difference, $V = 220 \text{ volts}$

current, $I = ?$

resistance, $R = 11000 \text{ ohms}$

Putting these values in the above formula, we get:

$$\frac{220}{I} = 11000$$

$$\text{So, } I = \frac{220}{11000} = 0.02 \text{ A}$$

Thus, the current flowing in the electric iron is 0.02 A .

(b) The heat energy in joules can be calculated by using the Joule's law heating

$$H = I^2 \times R \times t$$

Here, current, $I = 0.02 \text{ A}$

resistance, $R = 11000 \Omega$

and time, $t = 10 \text{ s}$

Putting these values in the above formula, we get

$$H = (0.02)^2 \times 11000 \times 10 = 44 \text{ J.}$$

27. For the same potential difference, the power and resistance of different appliances are related as $P \propto \frac{1}{R}$. This

means higher the resistance, lesser will be the power of the appliance.

If a same amount of current is passing through different appliances then power of an appliance is related to the resistance as $P \propto R$, i.e., higher the resistance, more is the power of appliance.

OR

In this case we have been given power P and voltage V , so the current will be :

$$P = V \times I$$

Here, power, $P = 40 \text{ watts}$

voltage, $V = 220 \text{ volts}$

and, current, $I = ?$

(To be calculated)

Now, putting these values in the above formula, we get :

$$40 = 220 \times I$$

$$I = \frac{40}{220} = \frac{2}{11}$$

Thus, current, $I = 0.18 \text{ ampere}$

28. (a) Bulbs B_1 , B_2 and B_3 are connected in parallel, so potential difference across each is same. When bulb B_1 gets fused, potential difference across B_2 and B_3 does not change, so, their glow remains unchanged.

(b) Let the resistance of each bulb be $R \Omega$, then net resistance of the circuit,

$$\frac{1}{R_p} = \frac{1}{R} + \frac{1}{R} + \frac{1}{R} = \frac{3}{R} \text{ or } R_p = \frac{R}{3} \Omega$$

Now, $I = 3 \text{ A}$, $V = 4.5 \text{ V}$

$$\therefore R_p = \frac{V}{I} \text{ or } \frac{R}{3} = \frac{4.5}{3} \text{ or } R = 4.5 \Omega$$

When bulb B_2 gets fused, no current flows through ammeter A_2 .

\therefore Resistance of the circuit,

$$\frac{1}{R_{\text{new}}} = \frac{1}{R} + \frac{1}{R} = \frac{2}{R} \text{ or } R_{\text{new}} = \frac{R}{2} = \frac{4.5}{2} \Omega$$

$$\therefore I_{\text{new}} = \frac{V}{R_{\text{new}}} = \frac{4.5 \times 2}{4.5} = 2 \text{ A}$$

This current divides equally in bulb B_1 and B_3 .

Therefore reading of A_1 , A_2 , A_3 and A are 1 A, 0, 1 A and 2 A respectively.

(c) When all the three bulbs glow, $I = 3 \text{ A}$, $V = 4.5 \text{ V}$

\therefore Power dissipated in the circuit, $P = VI$

$$= 3 \text{ A} \times 4.5 \text{ V} = 13.5 \text{ W}$$

29. First of all we will calculate the resistance of electric heater. Now, in the first case, the electric heater draws a current of 3.4 A from 220 V supply line. So, potential difference, $V = 220 \text{ V}$

Current, $I = 4 \text{ A}$ and resistance, $R = ?$

$$\text{Now, } \frac{V}{I} = R$$

\therefore Resistance, $R = 55 \text{ W}$

Thus, the resistance of electric heater is 55 ohms. This resistance will now be used to find out the current drawn when the electric heater is connected to 110 V supply line. So,

$$\frac{V}{I} = R \Rightarrow \frac{110}{I} = 55$$

$$\therefore \text{Current, } I = \frac{110}{55} = 2 \text{ A}$$

30. Since electric heater has more power than an electric bulb and power is reciprocal to resistance for a given supply voltage (i.e., $P \propto 1/R$), therefore, the resistance of heater coil is less than that of electric bulb.

When the heater, which is connected in parallel with the illuminating bulb is switched on, it draws more current from the current supplied. Due to it, the bulb becomes dim, as current through bulb decreases. After sometime, the heater coil becomes hot. Its resistance increases. Current through heater coil decreases and in turn current through the lamp increases. Also, the supply of current increases to maintain the required voltage. Due to it, the dimness of the bulb decreases.

31. (a) Ratio of potential difference and current is known as resistance.

(b)

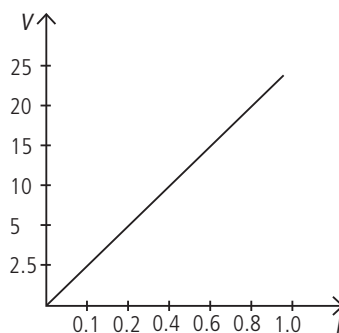

$$\text{Resistance, } R = \frac{\Delta V}{\Delta I} = \frac{20 - 10}{0.8 - 0.4} = \frac{10}{0.4} = 25 \Omega$$

(c) Ohm's law is illustrated by $V-I$ graph.

32. Join three resistors of different values in series. Connect them with a battery, an ammeter and a plug key, as shown in figure. We may use the resistors R_1 , R_2 , R_3 etc., and a battery of potential difference V for performing this activity.

Plug the key. Note the ammeter reading.

Change the position of ammeter to anywhere in between the resistors. Note the ammeter reading each time.

It is observed that the value of the current in the ammeter is the same, independent of its position in the electric circuit. It means that in a series combination of resistors, the current is the same in every part of the circuit or the same current through each resistor.

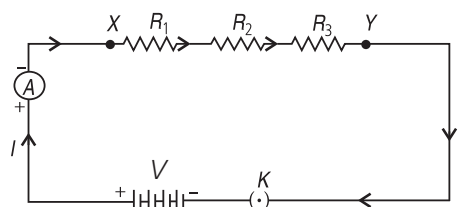

33. Here we know the voltage and power of the bulb. So, resistance can be calculated by using,

$$P = \frac{V^2}{R}$$

Here, power, $P = 100 \text{ watts}$

voltage, $V = 220 \text{ volts}$

and, resistance, $R = ?$

Now, putting these values in the above formula, we get:

$$100 = \frac{(220)^2}{R} \Rightarrow 100 R = 48400$$

$$\Rightarrow R = \frac{48400}{100} = 484 \text{ ohms}$$

The electrical energy consumed in kilowatt-hours can be calculated by using,

$$E = P \times t$$

Here, power, $P = 100$ watts

$$= \frac{100}{1000} \text{ kilowatt} = 0.1 \text{ kilowatt}$$

and time, $t = 7$ hours

$$\begin{aligned} \text{So, energy consumed by 1 bulb} &= 0.1 \times 7 \\ &= 0.7 \text{ kilowatt-hours} \end{aligned}$$

$$\begin{aligned} \text{And, energy consumed by 5 bulbs} &= 0.7 \times 5 \\ &= 3.5 \text{ kilowatt-hours (or 3.5 kWh)} \end{aligned}$$

34. The following circuit diagram depicts the parallel connection of three resistors R_1 , R_2 and R_3 .

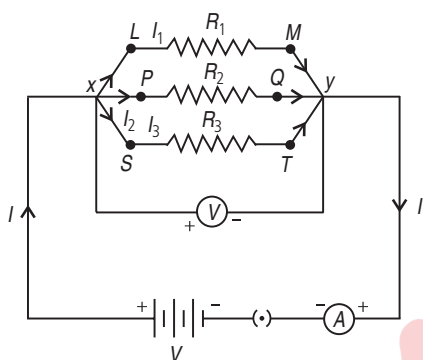

Let currents I_1 , I_2 and I_3 flow through the resistors R_1 , R_2 and R_3 respectively.

It is observed that total current I is equal to the sum of the separate currents through each branch.

$$\text{So, } I = I_1 + I_2 + I_3 \quad \dots(i)$$

Let R_p be the equivalent resistance. Then,

$$I = \frac{V}{R_p}$$

On applying Ohm's law to each resistor,

$$I_1 = \frac{V}{R_1}, \quad I_2 = \frac{V}{R_2}, \quad I_3 = \frac{V}{R_3}$$

From equation (i), we have

$$\frac{V}{R_p} = \frac{V}{R_1} + \frac{V}{R_2} + \frac{V}{R_3} \quad \text{or} \quad \frac{1}{R_p} = \frac{1}{R_1} + \frac{1}{R_2} + \frac{1}{R_3}$$

Voltmeter is connected in parallel across the resistor whose potential difference is to measure and ammeter is connected in series with resistor in the circuit.

OR

(a) Resistors are said to be connected in series, if the same current is flowing through each resistor when some potential difference is applied across the combination. Here the resistors are connected end to end with one another.

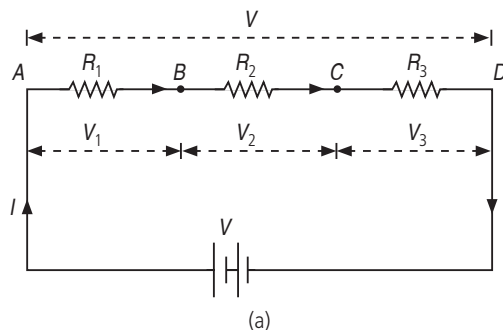

(a)

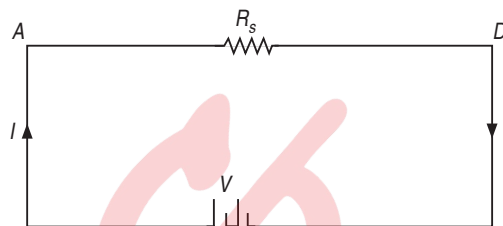

(b)

In figure three resistance wires AB , BC and CD are connected in series. Suppose their resistances are respectively R_1 , R_2 and R_3 . Let the equivalent resistance of these resistances be R_s . Suppose a current I is flowing in all the three resistances. Suppose the potential differences between the ends of the resistances R_1 , R_2 and R_3 are respectively V_1 , V_2 and V_3 .

$$\therefore V_1 = IR_1, \quad V_2 = IR_2 \text{ and } V_3 = IR_3.$$

If the potential difference between A and D be V , then

$$\begin{aligned} V &= V_1 + V_2 + V_3 \\ &= IR_1 + IR_2 + IR_3 \\ &= (R_1 + R_2 + R_3)I \quad \dots(i) \end{aligned}$$

The equivalent resistance between A and D is R_s . Therefore,

$$V = IR_s \quad \dots(ii)$$

Comparing eq. (i) and (ii), we get

$$IR_s = I(R_1 + R_2 + R_3)$$

$$\text{or } R_s = R_1 + R_2 + R_3$$

(b) Given circuit can be redrawn as follows :

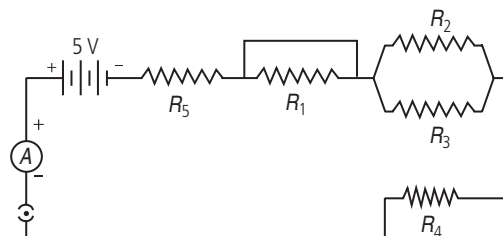

- (i) Resistors, R_5 and R_4 are connected in series.
- (ii) Resistors, R_2 and R_3 are connected in parallel.
- (iii) R_1 is shorted, hence it will not contribute to the circuit.

Equivalent resistance of R_2 and R_3 will be

$$\frac{1}{R'} = \frac{1}{R_2} + \frac{1}{R_3} = \frac{1}{2} + \frac{1}{2}$$

$$\frac{1}{R'} = \frac{1}{1} \quad \text{or} \quad R' = 1 \Omega$$

Then R' is connected in series with R_4 and R_5 .

So, equivalent resistance of the circuit is

$$R_{\text{eq}} = R' + R_4 + R_5 = 1 + 2 + 2 = 5 \Omega$$

$$\text{Using Ohm's law, } I = \frac{V}{R_{\text{eq}}} = \frac{5}{5} = 1 \text{ A}$$

So, total current flowing in the circuit will be 1 A.

35. Ohm's law states that the electric current flowing through a metallic wire is directly proportional to the potential difference V , across its ends provided its temperature remains the same.

$$V \propto I \quad \text{or} \quad \frac{V}{I} = \text{constant} = R$$

$$\text{or} \quad V = IR$$

To experimentally verify Ohm's law, an electric circuit as shown in figure is set up which contains the following components.

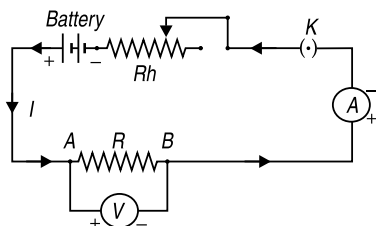

- (i) A battery which is used to send current in the circuit.
- (ii) A rheostat (Rh) which is a variable resistance and is used to change and adjust current in the circuit.
- (iii) A resistance wire AB of fixed resistance R .
- (iv) An ammeter (A) which is used to measure current in the circuit (*i.e.*, current through R). It is connected in series with the resistance R so that the current through A is the same as that passing through R . Also note that the +ve terminal of A is connected to positive terminal of the battery and its -ve terminal is connected to the negative terminal of the battery.
- (v) A voltmeter (V) is connected in parallel across R to measure potential difference between the point A and B of the resistance wire. Again, note that the +ve terminal of V goes to positive terminal of the battery and the -ve terminal goes to negative terminal of the battery.
- (vi) A plug key, K is used to open or close the circuit as and when required.

When the key K is closed, a current starts flowing in the circuit. The current in the circuit is changed by adjusting the rheostat and the readings of V and A are taken. These readings give us the values of potential difference (V) across R and the current (I) flowing through it.

It is found that V/I is practically constant, *i.e.*, $\frac{V}{I} = \text{constant}$ or $V \propto I$. This verifies Ohm's law.

Ohm's law does not hold good under all conditions. It is obeyed by metallic conductors only when physical conditions like temperature etc. remain unchanged.

OR

Resistivity is numerically equal to the resistance of a wire of unit length having a unit area of cross-section. Its SI unit is ohm-metre ($\Omega \text{ m}$).

Make an electric circuit consisting of a cell, an ammeter, a nichrome wire of length l [say, marked (1)] and a plug key, as shown in figure.

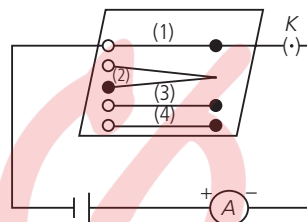

- (i) Now, plug the key. Note the current in the ammeter.
- (ii) Replace the nichrome wire by another nichrome wire of same thickness but twice the length, that is $2l$ [marked (2)] in the figure.
- (iii) Note the ammeter reading.
- (iv) Now replace the wire by a thicker nichrome wire, of the same length l [marked (3)]. A thicker wire has a larger cross-sectional area. Again note down the current through the circuit.
- (v) Instead of taking a nichrome wire, connect a copper wire [marked (4) in figure] in the circuit. Let the wire be of the same length and same area of cross-section as that of the first nichrome wire [marked (1)]. Note the value of the current.
- (vi) Notice the difference in the current in all cases.

It is observed that the ammeter reading decreases to one-half when the length of the wire is doubled. The ammeter reading is increased when a thicker wire of the same material and of the same length is used in the circuit. A change in ammeter reading is observed when a wire of different material of the same length and the same area of cross-section is used. On applying Ohm's law, we observe that the resistance of the conductor depends (i) on its length, (ii) on its area of cross-section, and (iii) on the nature of its material.

36. (a) When the bulbs are in series, current $I = \text{constant}$. As $P = I^2 R$, so $P \propto R$. Hence, the lamp with higher resistance (*i.e.*, R_1) will glow more brightly.

(b) When the two bulbs are operating in series, total illumination, $P = \frac{V^2}{(R_1 + R_2)}$.

When the lamp of resistance R_2 gets burned and bulb of resistance R_1 alone is operated, then illumination, $P' = \frac{V^2}{R_1}$, i.e., $P' > P$.

So, the net illumination will increase.

(c) When the bulbs are in parallel, voltage across each bulb is same, as,

$$P = \frac{V^2}{R}, \text{ so } P \propto \frac{1}{R}.$$

Hence, the lamp with lower resistance (i.e., R_2) will glow brightly.

(d) When both the bulbs are operating in parallel, then total illumination,

$$P = P_1 + P_2 = \frac{V^2}{R_1} + \frac{V^2}{R_2}$$

When lamp of resistance R_1 burns out, only lamp of resistance R_2 will give light. Then illumination is

$$P' = \frac{V^2}{R_2}, \text{ i.e., } P' < P.$$

So, the net illumination will decrease.

OR

In the first case :

Power, $P = 1000 \text{ W}$

Potential difference, $V = 220 \text{ V}$

And, resistance, $R = ?$

$$\text{Now, } P = \frac{V^2}{R}$$

$$\text{So, } 1000 = \frac{(220)^2}{R}$$

$$\text{and } R = \frac{220 \times 220}{1000} = 48.4 \Omega$$

This resistance of 48.4Ω of the bulb will remain unchanged.

In the second case :

Power, $P = ?$

Potential difference, $V = 110 \text{ V}$

And, resistance, $R = 48.4 \Omega$

$$\text{Now, } P = \frac{V^2}{R}$$

$$\therefore P = \frac{(110)^2}{48.4} = \frac{110 \times 110}{48.4} = 250 \text{ W}$$

